Activity 3.1b Linear Measurement with US Customary Units

Introduction

The United States is the only developed country that does not use the International System of Units. The U S Customary units are the accepted units of measure. However, due to the global nature of the economy, SI units are also common. In order to participate in the global market, we must be able to understand and communicate using various measurement systems.

In this activity you will practice taking linear measurements using a standard ruler marked in US Customary units and correctly recording the measurements to reflect the precision of the measurement.

Equipment

- Engineering notebook
- Pencil
- Ruler – U S Customary
- PLTW Engineering Formula Sheet

Procedure

Record the length of each rectangle in both fractional inch and decimal inch forms. Record fractional inches to the nearest $\frac{1}{32}$ of an inch, and record decimal inches to the nearest hundredth of an inch.

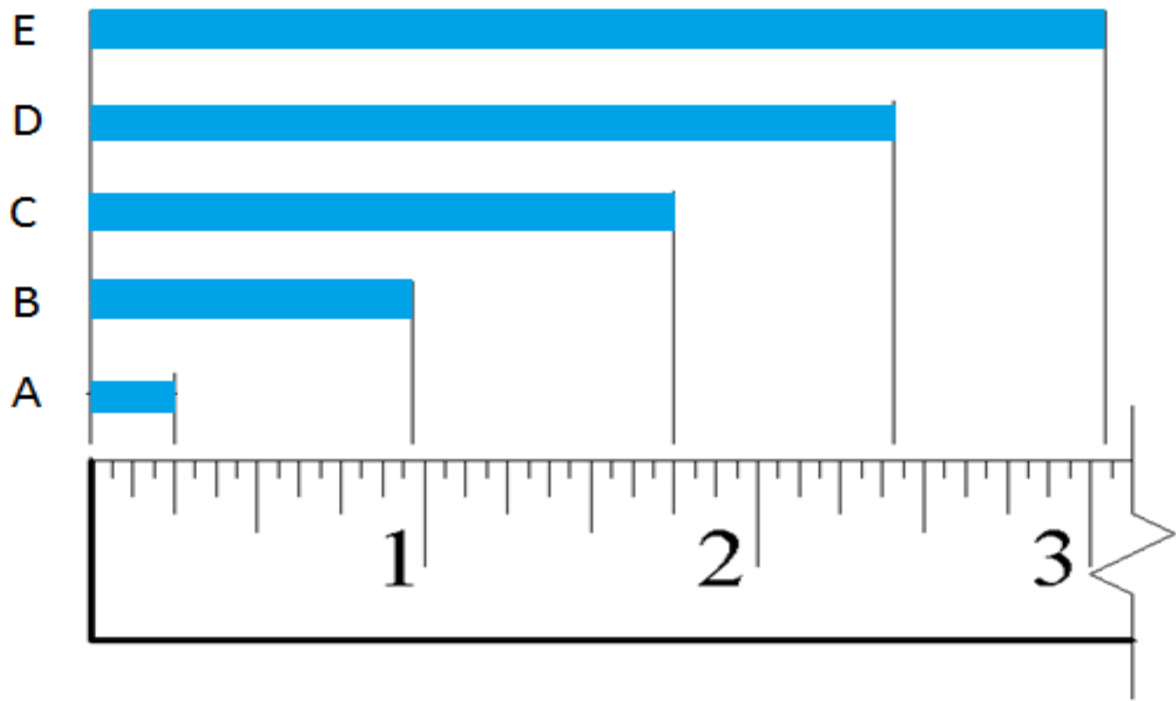

	Distance	Measurement (Fraction)	Measurement (Decimal)
1.	A		
2.	B		
3.	C		
4.	D		
5.	E		

6. What is the difference in length between rectangles A and C?

7. What is the difference in length between rectangles B and E?

8. Using a ruler displaying U S Customary units, measure the missing lengths in the figure below. In the top half of each box, enter the dimension in fractional inches to appropriate precision (nearest 1/32"). Then convert the length to decimal inches and enter the result into the bottom half of the corresponding box to the nearest hundredth of an inch. Be sure to include units. Note that \varnothing indicates a diameter, and R indicates a radius.

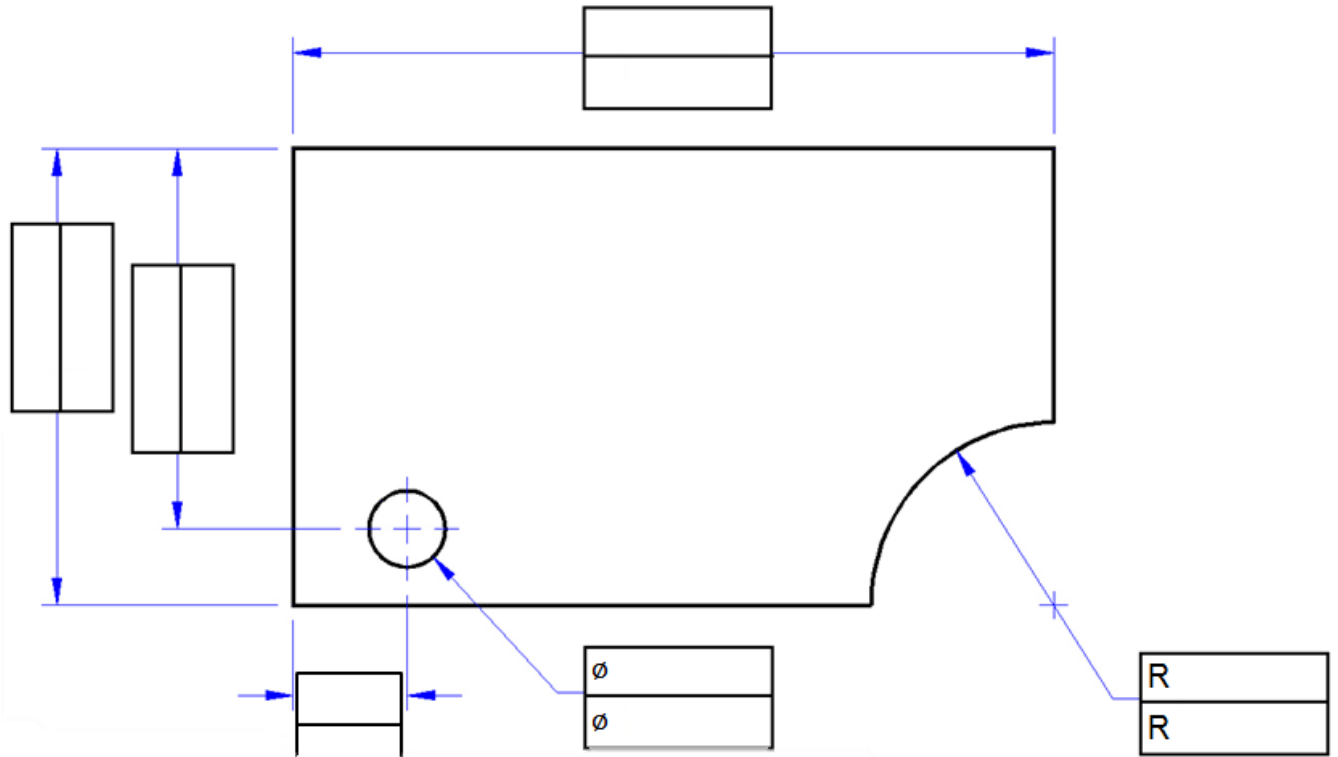

9. Measure the distance between two adjacent lines on a sheet of lined paper in US Customary units. Record the measurements using each of the following units.

Fractional inches: _____ [Decimal inches: _____]

10. Measure and record the length of additional items in your classroom using appropriate measurement units as directed by your instructor. Record fractional inches to the nearest $\frac{1}{32}$ " and decimal inches to the nearest hundredth of an inch.

Object	Description of measurement	Measurement units	Measurement
CD	Diameter	cm	
Desk	Length and width	Decimal inches	

11. In your engineering notebook, create a full scale isometric view of the object represented in the following sketch using the dimensions shown. Use a ruler to obtain the correct dimensions on your sketch.

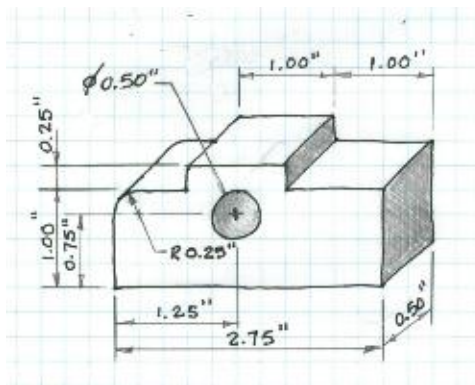

Conclusion

1. When you look at a drawing, how do you know if you are looking at U S Customary or SI measurements? Why is it important for an engineer to know this piece of information?